

HOCHLEISTUNGSBEARBEITUNG
- für Graphitwerkstoffe -

Graphit / Graphite

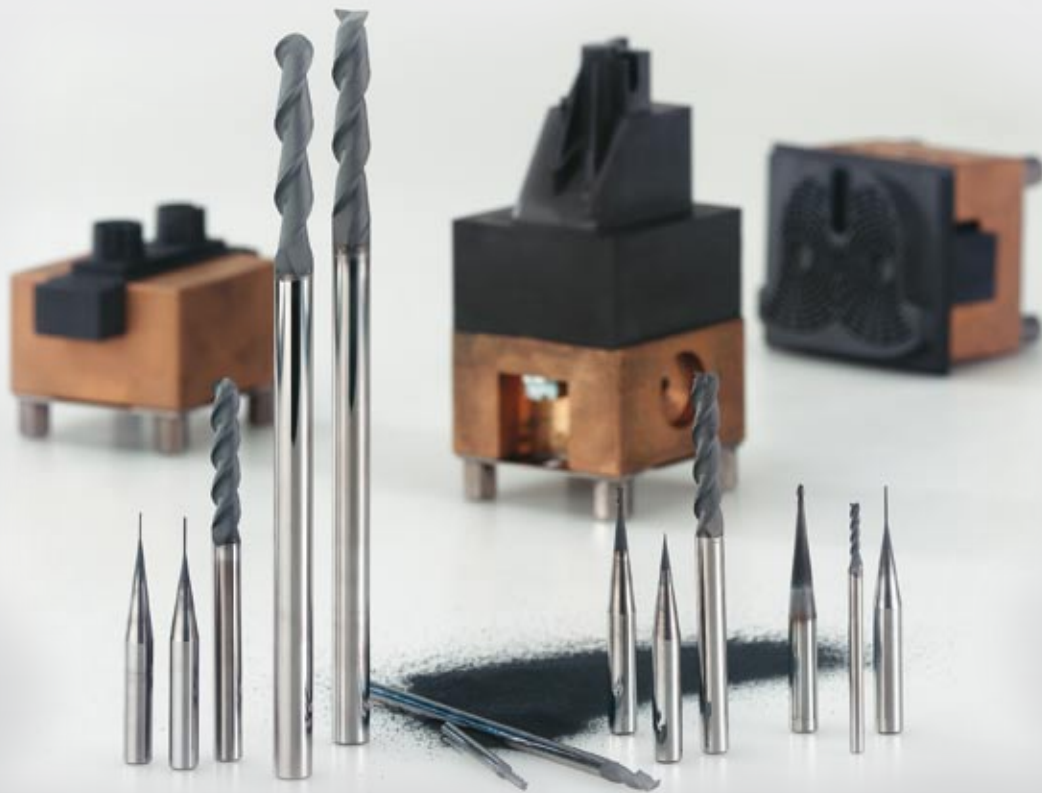

HIGH PRODUCTIVE MACHINING
- for graphite materials -

**Graphit
Graphite**

| | Typ Type | Seite Page |
|--|---------------|---------------|
| Schaftfräser Vollradius 2-Schneider / 3-Schneider Endmill Ballnose 2-fluted / 3-fluted | DSKG / DSKGL | M14-M15 |
| Torusfräser 2-/3-Schneider mit Eckenradius Torus Endmill 2-/3-fluted with Corner radius | DSTG / DSTLG | M16-M18 |
| Schruppfräser Roughing Endmill | DSVG | M19 |
| Microfräser Vollradius 2-Schneider mit Eckenradius Micro Endmill Ballnose 2-fluted with Corner radius | DSKMG / DSMMG | M20-M21 |
| Formeln Formulas | | M65-M66 |
| Schnittdaten Cutting data | | M67, M74-M79 |

SCHAFTFRÄSER Vollradius

BALLNOSE ENDMILL



für Graphit
for graphite

DSKG

3-schneidig, 40° Drallwinkel
3-fluted, 40° helix angle

Schnittdatenempfehlung Seite M74
recommended cutting data page M74

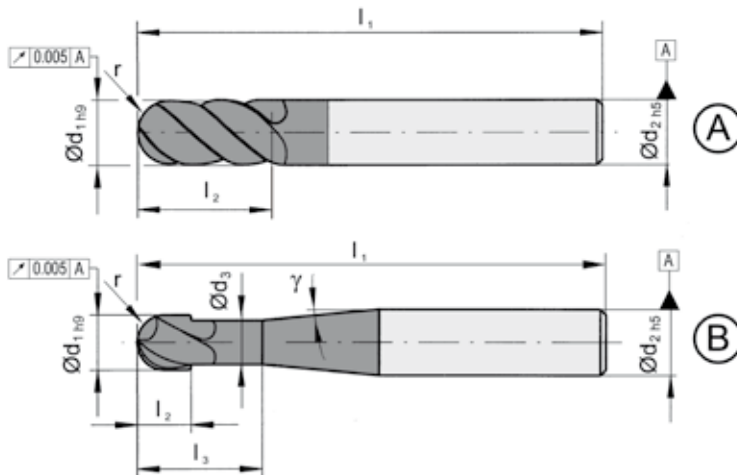

Standard
Standard

| Bestellnummer Part number | d ₁ | d ₂ | d ₃ | l ₁ | l ₂ | l ₃ | r | Z | γ | Ausführung Version | CD5K |
|------------------------------|----------------|----------------|----------------|----------------|----------------|----------------|-----|---|-----|-----------------------|------|
| DSKG.3.06.77.06 | 6 | 6 | - | 77 | 32 | - | 3,0 | 3 | - | A | ▲ |
| DSKG.3.08.77.08 | 8 | 8 | - | 77 | 32 | - | 4,0 | 3 | - | A | ▲ |
| DSKG.3.10.77.10 | 10 | 10 | - | 77 | 32 | - | 5,0 | 3 | - | A | ▲ |
| DSKG.3.12.77.12 | 12 | 12 | - | 77 | 32 | - | 6,0 | 3 | - | A | ▲ |
| DSKG.3.02.50.04.L20 | 2 | 4 | 1,9 | 50 | 12 | 20 | 1,0 | 3 | 15° | B | ▲ |
| DSKG.3.02.63.06.L25 | 2 | 6 | 1,9 | 63 | 12 | 25 | 1,0 | 3 | 15° | B | ▲ |
| DSKG.3.03.50.04.L20 | 3 | 4 | 2,9 | 50 | 12 | 20 | 1,5 | 3 | 15° | B | ▲ |
| DSKG.3.03.63.06.L25 | 3 | 6 | 2,9 | 63 | 12 | 25 | 1,5 | 3 | 15° | B | ▲ |
| DSKG.3.04.63.06.L30 | 4 | 6 | 3,8 | 63 | 16 | 30 | 2,0 | 3 | 15° | B | ▲ |
| DSKG.3.05.63.06.L30 | 5 | 6 | 4,8 | 63 | 22 | 30 | 2,5 | 3 | 15° | B | ▲ |

▲ ab Lager / on stock Δ 4 Wochen / 4 weeks

● Haupteinsatzbereich / main recommendation

○ bedingt einsetzbar / alternative recommendation

■ unbeschichtete HM-Sorten / uncoated grades

■ beschichtete HM-Sorten / coated grades

■ bestückt/Cermet / brazed/Cermet

Abmessungen in mm
Dimensions in mm

| | |
|---|---|
| P | ▲ |
| M | ▲ |
| K | ▲ |
| S | ▲ |
| N | ○ |
| H | ▲ |

HM-Sorten
Carbide grades

Diamantbeschichtet
Diamond coated

Graphit / Graphite

SCHAFTFRÄSER Vollradius

BALLNOSE ENDMILL



für Graphit
for graphite

DSKGL

2-schneidig, 40° Drallwinkel
2-fluted, 40° helix angle

Schnittdatenempfehlung Seite M75
recommended cutting data page M75

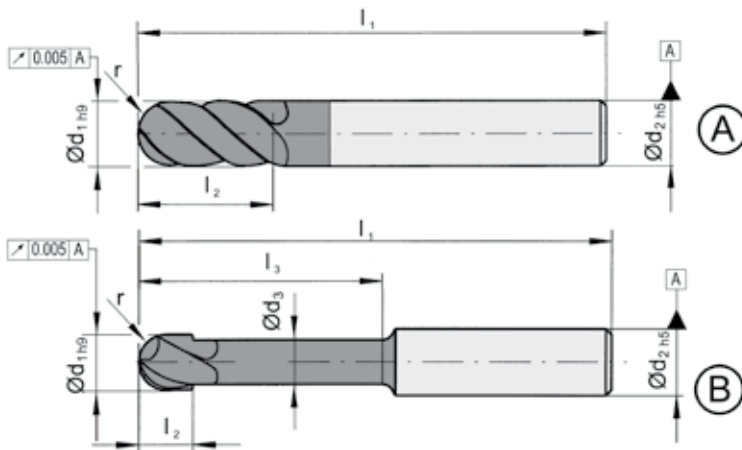

lange Ausführung
long reach

| Bestellnummer Part number | d ₁ | d ₂ | d ₃ | l ₁ | l ₂ | l ₃ | r | Z | Ausführung Version | CD5K |
|------------------------------|----------------|----------------|----------------|----------------|----------------|----------------|-----|---|-----------------------|------|
| DSKGL.2.06.099.06 | 6 | 6 | 5,6 | 99 | 20 | 45 | 3,0 | 2 | A | ▲ |
| DSKGL.2.08.149.08 | 8 | 8 | 7,6 | 149 | 20 | 60 | 4,0 | 2 | A | ▲ |
| DSKGL.2.10.149.10 | 10 | 10 | 9,6 | 149 | 20 | 75 | 5,0 | 2 | A | ▲ |
| DSKGL.2.12.149.12 | 12 | 12 | 11,6 | 149 | 25 | 75 | 6,0 | 2 | A | ▲ |
| DSKGL.2.02.099.04 | 2 | 4 | 1,9 | 99 | 5 | 10 | 1,0 | 2 | B | ▲ |
| DSKGL.2.03.099.04 | 3 | 4 | 2,9 | 99 | 8 | 15 | 1,5 | 2 | B | ▲ |
| DSKGL.2.04.099.06 | 4 | 6 | 3,8 | 99 | 15 | 30 | 2,0 | 2 | B | ▲ |

- ▲ ab Lager / on stock Δ 4 Wochen / 4 weeks
- Haupteinsatzbereich / main recommendation
- o bedingt einsetzbar / alternative recommendation
- unbeschichtete HM-Sorten / uncoated grades
- beschichtete HM-Sorten / coated grades
- bestückt/Cermet / brazed/Cermet

Abmessungen in mm
Dimensions in mm

| |
|---|
| P |
| M |
| K |
| S |
| N |
| H |

HM-Sorten
Carbide grades

Diamantbeschichtet
Diamond coated

Graphit / Graphite

TORUSFRÄSER

TORUS ENDMILL



für Graphit
for graphite

DSTG

3-schneidig, 40° Drallwinkel, mit Eckenradius
3-fluted, 40° helix angle, with corner radius

Schnittdatenempfehlung Seite M76
recommended cutting data page M76

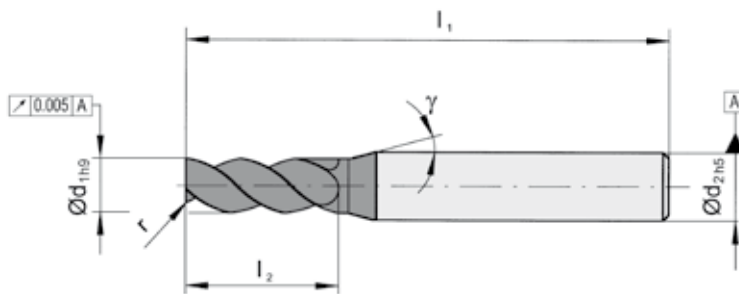

Graphit / Graphite

| Bestellnummer Part number | d ₁ | d ₂ | l ₁ | l ₂ | r | Z | γ | CD5K |
|------------------------------|----------------|----------------|----------------|----------------|-----|---|-----|------|
| DSTG.3.02.1.50.04 | | 4 | 50 | | 0,1 | | | ▲ |
| DSTG.3.02.3.50.04 | 2 | 4 | 50 | 12 | 0,3 | 3 | 15° | ▲ |
| DSTG.3.02.1.63.06 | | 6 | 63 | | 0,1 | | | ▲ |
| DSTG.3.02.3.63.06 | | 6 | 63 | | 0,3 | | | ▲ |
| DSTG.3.03.1.50.04 | | 4 | 50 | | 0,1 | | | ▲ |
| DSTG.3.03.3.50.04 | 3 | 4 | 50 | 12 | 0,3 | 3 | 15° | ▲ |
| DSTG.3.03.1.63.06 | | 6 | 63 | | 0,1 | | | ▲ |
| DSTG.3.03.3.63.06 | | 6 | 63 | | 0,3 | | | ▲ |
| DSTG.3.04.2.63.06 | 4 | 6 | 63 | 16 | 0,2 | 3 | 15° | ▲ |
| DSTG.3.04.5.63.06 | | | | | 0,5 | | | ▲ |
| DSTG.3.05.2.63.06 | 5 | 6 | 63 | 22 | 0,2 | 3 | 15° | ▲ |
| DSTG.3.05.5.63.06 | | | | | 0,5 | | | ▲ |

- ▲ ab Lager / on stock Δ 4 Wochen / 4 weeks
- Haupteinsatzbereich / main recommendation
- o bedingt einsetzbar / alternative recommendation
- unbeschichtete HM-Sorten / uncoated grades
- beschichtete HM-Sorten / coated grades
- bestückt/Cermet / brazed/Cermet

| |
|---|
| P |
| M |
| K |
| S |
| N |
| H |

Abmessungen in mm
Dimensions in mm

HM-Sorten
Carbide grades
Diamantbeschichtet
Diamond coated

für Graphit
for graphite

DSTG

3-schneidig, 40° Drallwinkel, mit Eckenradius
3-fluted, 40° helix angle, with corner radius

Schnittdatenempfehlung Seite M76
recommended cutting data page M76

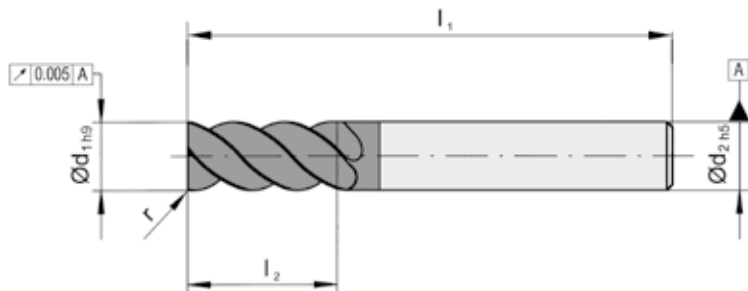

Graphit / Graphite

| Bestellnummer Part number | d ₁ | d ₂ | l ₁ | l ₂ | r | Z | CD5K |
|------------------------------|----------------|----------------|----------------|----------------|-----|---|------|
| DSTG.3.06.3.77.06 | 6 | 6 | | | 0,3 | | ▲ |
| DSTG.3.06.5.77.06 | 6 | 6 | 77 | 32 | 0,5 | 3 | ▲ |
| DSTG.3.06.10.77.06 | 6 | 6 | | | 1,0 | | ▲ |
| DSTG.3.08.3.77.08 | 8 | 8 | | | 0,3 | | ▲ |
| DSTG.3.08.5.77.08 | 8 | 8 | 77 | 32 | 0,5 | 3 | ▲ |
| DSTG.3.08.10.77.08 | 8 | 8 | | | 1,0 | | ▲ |
| DSTG.3.10.3.77.10 | 10 | 10 | | | 0,3 | | ▲ |
| DSTG.3.10.5.77.10 | 10 | 10 | 77 | 32 | 0,5 | 3 | ▲ |
| DSTG.3.10.10.77.10 | 10 | 10 | | | 1,0 | | ▲ |
| DSTG.3.12.3.77.12 | 12 | 12 | | | 0,3 | | ▲ |
| DSTG.3.12.5.77.12 | 12 | 12 | 77 | 32 | 0,5 | 3 | ▲ |
| DSTG.3.12.10.77.12 | 12 | 12 | | | 1,0 | | ▲ |

- ▲ ab Lager / on stock Δ 4 Wochen / 4 weeks
- Haupteinsatzbereich / main recommendation
- o bedingt einsetzbar / alternative recommendation
- unbeschichtete HM-Sorten / uncoated grades
- beschichtete HM-Sorten / coated grades
- bestückt/Cermet / brazed/Cermet

| |
|---|
| P |
| M |
| K |
| S |
| N |
| H |

Abmessungen in mm
Dimensions in mm

HM-Sorten
Carbide grades

Diamantbeschichtet
Diamond coated

für Graphit
for graphite

DSTLG

2-schneidig, 40° Drallwinkel, mit Eckenradius
2-fluted, 40° helix angle, with corner radius

Schnittdatenempfehlung Seite M76
recommended cutting data page M76

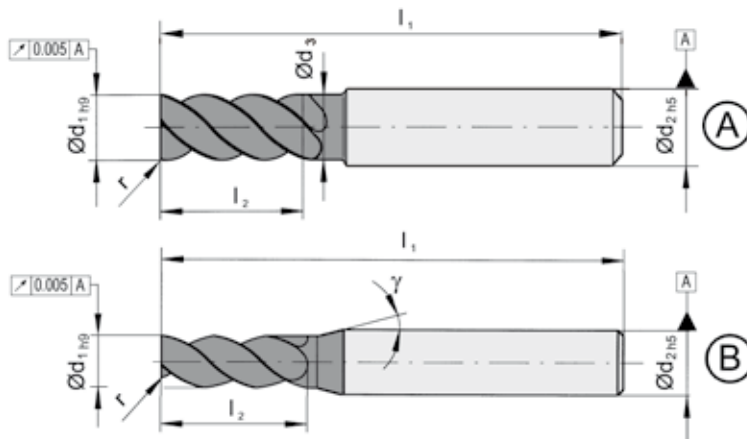

lange Ausführung
long reach

| Bestellnummer Part number | d ₁ | d ₂ | d ₃ | l ₁ | l ₂ | l ₃ | r | Z | γ | Ausführung Version | CD5K |
|------------------------------|----------------|----------------|----------------|----------------|----------------|----------------|-----|---|-----|-----------------------|------|
| DSTLG.2.06.5.099.06 | 6 | 6 | 5,6 | 99 | 20 | 45 | 0,5 | 2 | - | A | ▲ |
| DSTLG.2.08.5.149.08 | 8 | 8 | 7,6 | 149 | 20 | 60 | 0,5 | 2 | - | A | ▲ |
| DSTLG.2.10.5.149.10 | 10 | 10 | 9,6 | 149 | 20 | 75 | 0,5 | 2 | - | A | ▲ |
| DSTLG.2.12.5.149.12 | 12 | 12 | 11,6 | 149 | 25 | 75 | 0,5 | 2 | - | A | ▲ |
| DSTLG.2.02.3.099.04 | 2 | 4 | 1,9 | 99 | 5 | 10 | 0,3 | 2 | 15° | B | ▲ |
| DSTLG.2.03.3.099.04 | 3 | 4 | 2,9 | 99 | 8 | 15 | 0,3 | 2 | 15° | B | ▲ |
| DSTLG.2.04.3.099.06 | 4 | 6 | 3,8 | 99 | 15 | 30 | 0,3 | 2 | 15° | B | ▲ |

▲ ab Lager / on stock Δ 4 Wochen / 4 weeks

● Haupteinsatzbereich / main recommendation

○ bedingt einsetzbar / alternative recommendation

■ unbeschichtete HM-Sorten / uncoated grades

■ beschichtete HM-Sorten / coated grades

■ bestückt/Cermet / brazed/Cermet

Abmessungen in mm
Dimensions in mm

| |
|---|
| P |
| M |
| K |
| S |
| N |
| H |

HM-Sorten
Carbide grades

Diamantbeschichtet
Diamond coated

SCHRUPPFRÄSER ROUGHING ENDMILL



für Graphit
for graphite

DSVG

mehrschneidig
multiple fluted

Schnittdatenempfehlung Seite M77
recommended cutting data page M77

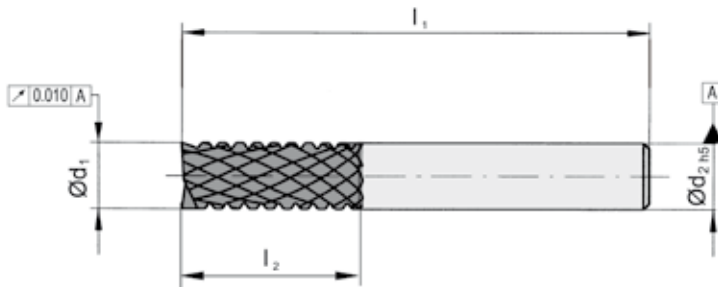

Graphit / Graphite

| Bestellnummer Part number | d ₁ | d ₂ | l ₁ | l ₂ | CD5K |
|------------------------------|----------------|----------------|----------------|----------------|------|
| DSVG.X.04.0.59.04 | 4 | 4 | 59 | 12 | ▲ |
| DSVG.X.06.0.77.06 | 6 | 6 | 77 | 18 | ▲ |
| DSVG.X.08.0.77.08 | 8 | 8 | 77 | 24 | ▲ |
| DSVG.X.10.0.77.10 | 10 | 10 | 77 | 30 | ▲ |
| DSVG.X.12.0.88.12 | 12 | 12 | 88 | 36 | ▲ |

- ▲ ab Lager / on stock Δ 4 Wochen / 4 weeks
- Haupteinsatzbereich / main recommendation
- o bedingt einsetzbar / alternative recommendation
- unbeschichtete HM-Sorten / uncoated grades
- beschichtete HM-Sorten / coated grades
- bestückt/Cermet / brazed/Cermet

Abmessungen in mm
Dimensions in mm

HM-Sorten
Carbide grades

Diamantbeschichtet
Diamond coated

für Graphit
for graphite

DSKMG

2-schneidig, 40° Drallwinkel
2-fluted, 40° helix angle

Schnittdatenempfehlung Seite M78
recommended cutting data page M78

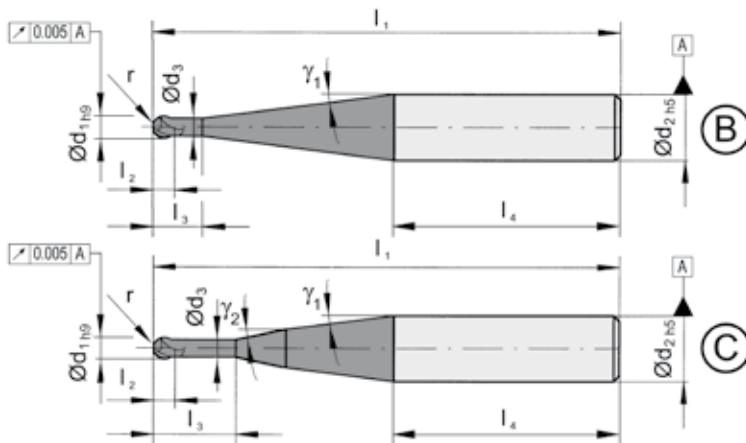

Graphit / Graphite

| Bestellnummer Part number | d ₁ | d ₂ | l ₁ | l ₂ | l ₃ | l ₄ | d ₃ | r | Z | γ ₁ | γ ₂ | Ausführung Version | CD5K |
|------------------------------|----------------|----------------|----------------|----------------|----------------|----------------|----------------|------|---|----------------|----------------|-----------------------|------|
| DSKMG.2.03.50.4.L40 | 0,3 | 4 | 50 | 2,0 | 4 | 36 | 0,25 | 0,15 | 2 | 10,6° | | B | ▲ |
| DSKMG.2.04.50.4.L50 | 0,4 | 4 | 50 | 2,0 | 5 | 36 | 0,35 | 0,20 | 2 | 11,5° | | B | ▲ |
| DSKMG.2.05.50.4.L40 | 0,5 | 4 | 50 | 2,0 | 4 | 36 | 0,45 | 0,25 | 2 | 10,1° | | B | ▲ |
| DSKMG.2.05.50.4.L60 | | | | | 6 | | | | | | | | |
| DSKMG.2.06.50.4.L70 | 0,6 | 4 | 50 | 2,5 | 7 | 36 | 0,55 | 0,30 | 2 | 13,8° | | B | ▲ |
| DSKMG.2.08.50.4.L80 | 0,8 | 4 | 50 | 2,5 | 8 | 36 | 0,75 | 0,40 | 2 | 15,2° | | B | ▲ |
| DSKMG.2.10.50.4.L10 | 1,0 | 4 | 50 | 3,5 | 10 | 36 | 0,90 | 0,50 | 2 | 21,2° | | B | ▲ |
| DSKMG.2.10.50.4.L60 | | | | | 6 | | | | | | | | |
| DSKMG.2.15.50.4.L10 | 1,5 | 4 | 50 | 3,5 | 10 | 36 | 1,40 | 0,75 | 2 | 18° | | B | ▲ |
| DSKMG.2.05.63.6.L40 | 0,5 | 6 | 63 | 2,0 | 4 | 40 | 0,45 | 0,25 | 2 | 9,5° | 5 | C | ▲ |
| DSKMG.2.05.63.6.L60 | | | | | 6 | | | | | | | | |
| DSKMG.2.10.63.6.L10 | 1,0 | 6 | 63 | 2,5 | 10 | 40 | 0,90 | 0,50 | 2 | 14,8° | 5 | C | ▲ |
| DSKMG.2.10.63.6.L60 | | | | 3,5 | | | | | | | | | |
| DSKMG.2.15.63.6.L10 | 1,5 | 6 | 63 | 3,5 | 10 | 40 | 1,40 | 0,75 | 2 | 13,1° | 5 | C | ▲ |

▲ ab Lager / on stock Δ 4 Wochen / 4 weeks

● Haupteinsatzbereich / main recommendation

○ bedingt einsetzbar / alternative recommendation

■ unbeschichtete HM-Sorten / uncoated grades

■ beschichtete HM-Sorten / coated grades

■ bestückt/Cermet / brazed/Cermet

Abmessungen in mm
Dimensions in mm

HM-Sorten
Carbide grades

Diamantbeschichtet
Diamond coated

für Graphit
for graphite

DSMMG

2-schneidig, 40° Drallwinkel, mit Eckenradius
2-fluted, 40° helix angle, with corner radius

Schnittdatenempfehlung Seite M79
recommended cutting data page M79

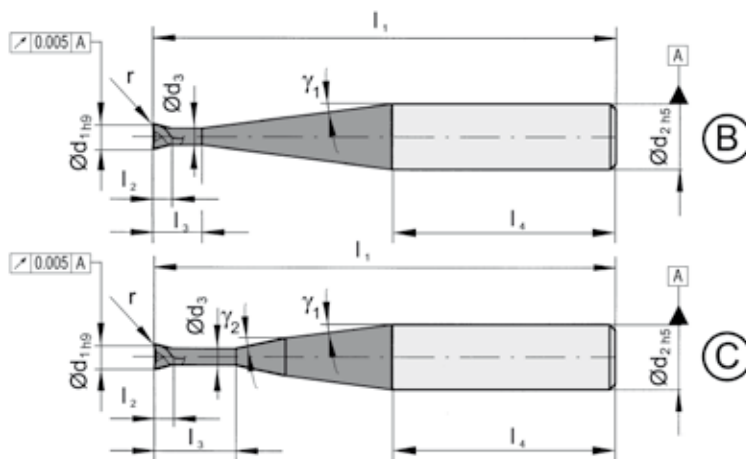

Graphit / Graphite

| Bestellnummer Part number | d ₁ | d ₂ | l ₁ | l ₂ | l ₃ | l ₄ | d ₃ | r | Z | γ ₁ | γ ₂ | Ausführung Version | CD5K |
|------------------------------|----------------|----------------|----------------|----------------|----------------|----------------|----------------|------|---|----------------|----------------|-----------------------|------|
| DSMMG.2.03.50.4.L40 | 0,3 | 4 | 50 | 2,0 | 4 | 36 | 0,25 | 0,05 | 2 | 10,6° | 0° | B | ▲ |
| DSMMG.2.04.50.4.L50 | 0,4 | 4 | 50 | 2,0 | 5 | 36 | 0,35 | 0,05 | 2 | 11,5° | 0° | B | ▲ |
| DSMMG.2.05.50.4.L40 | 0,5 | 4 | 50 | 2,0 | 4 | 36 | 0,45 | 0,05 | 2 | 10,1° | 0° | B | ▲ |
| DSMMG.2.05.50.4.L60 | | | | | 6 | | | | | 12,5° | | | ▲ |
| DSMMG.2.06.50.4.L70 | 0,6 | 4 | 50 | 2,5 | 7 | 36 | 0,55 | 0,05 | 2 | 13,8° | 0° | B | ▲ |
| DSMMG.2.08.50.4.L80 | 0,8 | 4 | 50 | 2,5 | 8 | 36 | 0,75 | 0,05 | 2 | 15,2° | 0° | B | ▲ |
| DSMMG.2.10.50.4.L10 | 1,0 | 4 | 50 | 3,5 | 10 | 36 | 0,90 | 0,05 | 2 | 21,2° | 0° | B | ▲ |
| DSMMG.2.10.50.4.L60 | | | | | 6 | | | | | 11° | | | ▲ |
| DSMMG.2.15.50.4.L10 | 1,5 | 4 | 50 | 3,5 | 10 | 36 | 1,40 | 0,05 | 2 | 18° | 0° | B | ▲ |
| DSMMG.2.05.63.6.L40 | 0,5 | 6 | 63 | 2,0 | 4 | 40 | 0,45 | 0,05 | 2 | 9,5° | 5° | C | ▲ |
| DSMMG.2.05.63.6.L60 | | | | | 6 | | | | | 11° | | | ▲ |
| DSMMG.2.10.63.6.L10 | 1,0 | 6 | 63 | 3,5 | 10 | 40 | 0,90 | 0,05 | 2 | 14,8° | 5° | C | ▲ |
| DSMMG.2.10.63.6.L60 | | | | | 6 | | | | | 10° | | | ▲ |
| DSMMG.2.15.63.6.L10 | 1,5 | 6 | 63 | 3,5 | 10 | 40 | 1,40 | 0,05 | 2 | 13,1° | 5° | C | ▲ |

▲ ab Lager / on stock Δ 4 Wochen / 4 weeks

● Haupteinsatzbereich / main recommendation

○ bedingt einsetzbar / alternative recommendation

■ unbeschichtete HM-Sorten / uncoated grades

■ beschichtete HM-Sorten / coated grades

■ bestückt/Cermet / brazed/Cermet

| |
|-----|
| P |
| M |
| K |
| S |
| N ○ |
| H |

Abmessungen in mm
Dimensions in mm

HM-Sorten
Carbide grades

Diamantbeschichtet
Diamond coated